

Only From Shock Tech

Shock-Tech's "Fluidic" (fluid filled) family of isolators were developed to provide solution for low frequency attenuation problems. They are ideal for applications where the prominent disturbing frequency is low, space to install an isolator is limited, and drift/creep associated with low frequency isolators will cause excessive static deflection, bottoming, resulting in performance fluctuations and causing premature equipment failure. If you have such a condition the Fluidic Mount is the solution to your vibration problem.

Performance depends on vibration input, the isolator chosen (FM10 thru FM78 series, see data sheets) and the environment. Resonant frequencies as low as 6 Hz. with maximum transmissibility of 2.25 can be obtained. This will allow for theoretical isolation of the mounted equipment at above 8-9 Hz. with no apprehensions for drift or creep problems associated with other commercially available isolators. Furthermore, material used to manufacture the Fluidic Mounts allow for a broad operational temperature range of -40⁰ to +160⁰ F. The Fluidic Mounts also provide long service life. Fluidic Mounts were subjected to accelerated fatigue testing and no serious performance degradation was observed after the test samples were subjected to 10 x 10⁶ cycles of vibration or 10,000 shock pulses.

Regarding mounting or installation of the fluidic isolators, optimum performance is obtained when the isolators are mounted in pure compression or angled, shear-compression mode. Mounting in pure shear or tension mode is not recommended.

The Fluidic Mounts are rated for different loads and conditions. These loads vary between .5-18 pounds for the FM10 series, 8-33 pounds for the FM20 series, and 30-290 pounds for the FM70 series. Furthermore the Fluidic Mounts size varies according to their rated load. Applications for these mounts are numerous, such as protection of electronic equipment mounted on off-road (HUMVEE) or tracked vehicles (M1A1, M1A2, M113, M577, M109, BFV...) or airborne environments and shipboard applications. Shock-Tech's FM series isolators are used extensively by the US Army to protect COTS equipment from MIL-STD shock and vibration environments.

CECOM has performed lab and field testing of the Fluidic Mounts for multiple programs for the protection of COTS electronics and has published a report titled "**VIBRATION QUALIFICATION OF COMMERCIAL COMPUTERS FOR USE IN MILITARY TACTICAL ENVIRONMENTS**". This report documents the results obtained and the conclusions derived using Shock-Tech's FM series isolators for protection of COTS equipment in military environments.

Please go to the end of this section for full transcript of the CECOM report.



FM10



FM20



FM76

CECOM Report

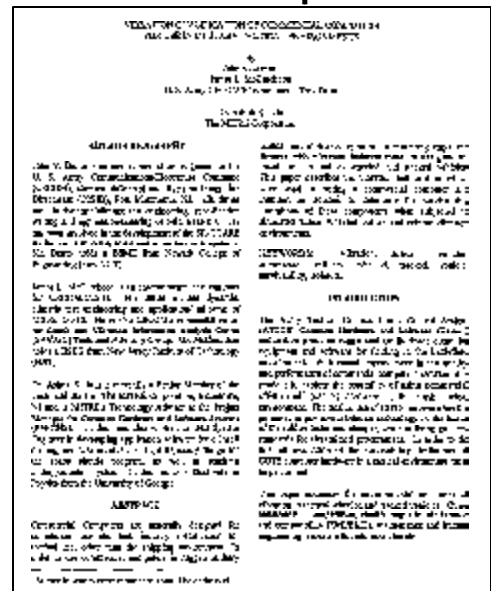

FM08 SERIES

Natural frequency	10-25 Hz	
Transmissibility at resonance	2.5 Max.	
Axial/Radial frequency ratio	1:0.7 approx.	
Resilient element	Neoprene	
Damping medium	VHDS silicone gel	
Metal parts	Stainless steel, passivated	
Operating Temperature	-40 to + 195 deg.F -40 to + 90 deg.C	
Weight	8 oz (227 grams)	
Part Number	Load Rating	
	Vehicular	Airborne
FM08-NO1	1-3 lbs	.25-2 lbs

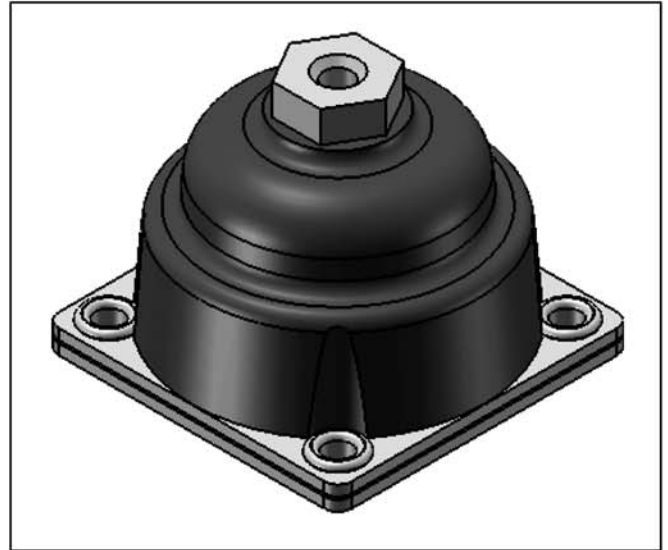

- **M113, M577, M1A1, M1A2, M109A6, BRADLEY:** Tested and specified by CECOM/TACOM for use per MIL-STD-810E for protection of COTS equipment

Characteristics

- Withstands high amplitude vibration inputs
- 0.5 inch Shock travel capability
- Outstanding dynamic fatigue life
- High vibration damping ratio, C/Cc = .20
- Axial-to-radial stiffness ratio of 1:0.5
- Less than 1.5% drift over 3 years under nominal load

Environment

- Operational temperature range of -40° to +195°F (-40°C to +90°C)
- Ozone, corrosion and fungus resistant

Installation

- No special tools required
- Can be made fail-safe by addition of a restraining strap
- Base (compression) or angled shear-compression mounting

How to order

- See load rating table for standard isolator
- Restraining strap available
- Metric Version: specify suffix M for M6 threaded core

CECOM report

A CECOM report titled "**Vibration qualification of commercial computers for use in military tactical environments**" documents the results obtained by CECOM during an extensive test program. Copy of the report is available from Shock-Tech, please ask for document FMCECOM/001

Applications

- Protection of commercial grade ground mobile and **COTS electronics on tracked vehicles** against military shock and vibration specifications
- Airborne electronics
- Shipboard equipment
- Trays and rack systems
- Meets MIL-STD-810E shock and vibration environments including ON THE MOVE requirements

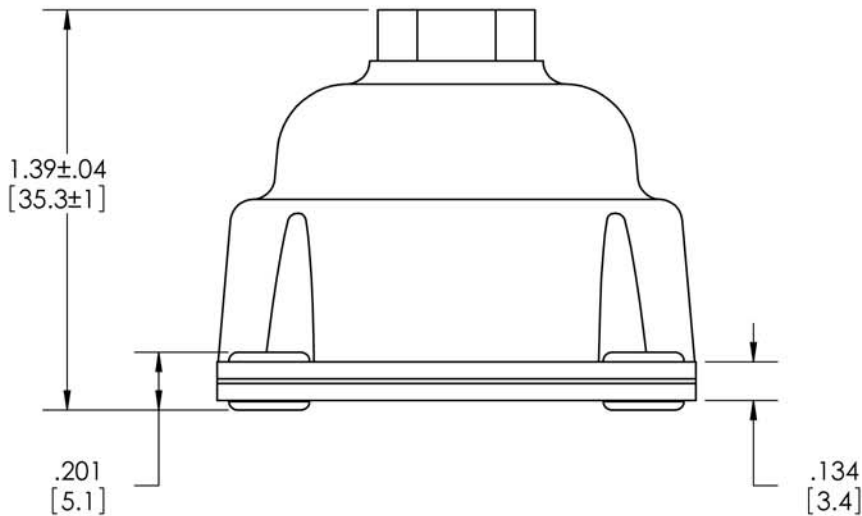
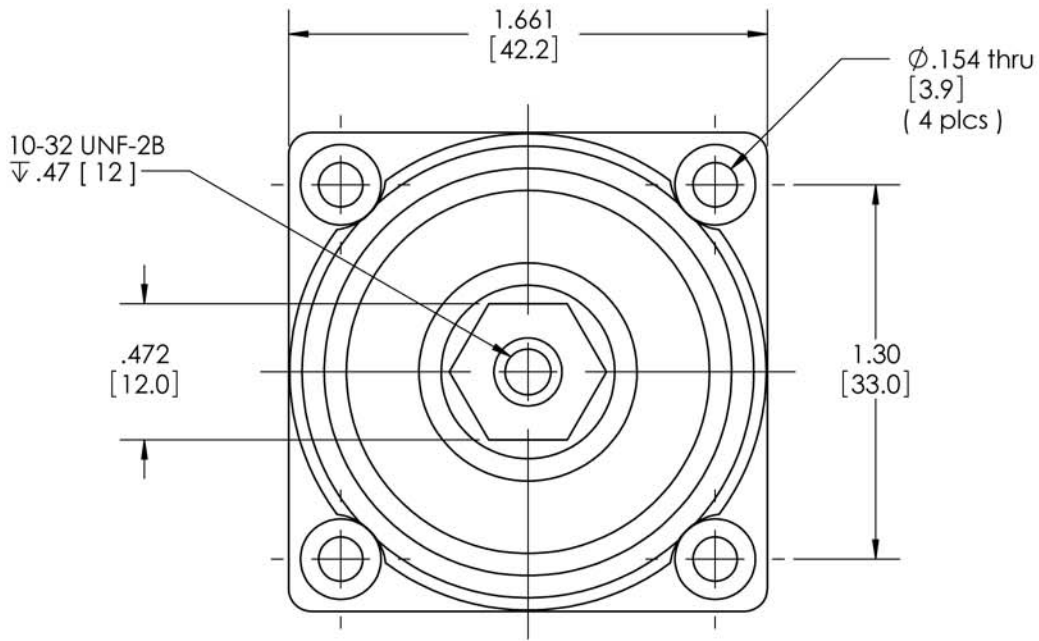

Only From Shock Tech

Shock-Tech's "Fluidic" (fluid filled) family of isolators were developed to provide solution for low frequency attenuation problems. They are ideal for applications where the prominent disturbing frequency is low, space to install an isolator is limited, and drift/creep associated with low frequency isolators will cause excessive static deflection, bottoming, resulting in performance fluctuations and causing premature equipment failure. If you have such a condition the Fluidic Mount is the solution to your vibration problem.

Performance depends on vibration input, the isolator chosen (FM10 thru FM78 series, see data sheets) and the environment. Resonant frequencies as low as 6 Hz. with maximum transmissibility of 2.25 can be obtained. This will allow for theoretical isolation of the mounted equipment at above 8-9 Hz. with no apprehensions for drift or creep problems associated with other commercially available isolators. Furthermore, material used to manufacture the Fluidic Mounts allow for a broad operational temperature range of -40⁰ to +160⁰ F. The Fluidic Mounts also provide long service life. Fluidic Mounts were subjected to accelerated fatigue testing and no serious performance degradation was observed after the test samples were subjected to 10 x 10⁶ cycles of vibration or 10,000 shock pulses.

Regarding mounting or installation of the fluidic isolators, optimum performance is obtained when the isolators are mounted in pure compression or angled, shear-compression mode. Mounting in pure shear or tension mode is not recommended.

The Fluidic Mounts are rated for different loads and conditions. These loads vary between .5-18 pounds for the FM10 series, 8-33 pounds for the FM20 series, and 30-290 pounds for the FM70 series. Furthermore the Fluidic Mounts size varies according to their rated load. Applications for these mounts are numerous, such as protection of electronic equipment mounted on off-road (HUMVEE) or tracked vehicles (M1A1, M1A2, M113, M577, M109, BFV...) or airborne environments and shipboard applications. Shock-Tech's FM series isolators are used extensively by the US Army to protect COTS equipment from MIL-STD shock and vibration environments.

CECOM has performed lab and field testing of the Fluidic Mounts for multiple programs for the protection of COTS electronics and has published a report titled "**VIBRATION QUALIFICATION OF COMMERCIAL COMPUTERS FOR USE IN MILITARY TACTICAL ENVIRONMENTS**". This report documents the results obtained and the conclusions derived using Shock-Tech's FM series isolators for protection of COTS equipment in military environments.

Please go to the end of this section for full transcript of the CECOM report.



FM10



FM20

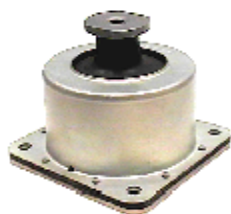

FM76

CECOM Report

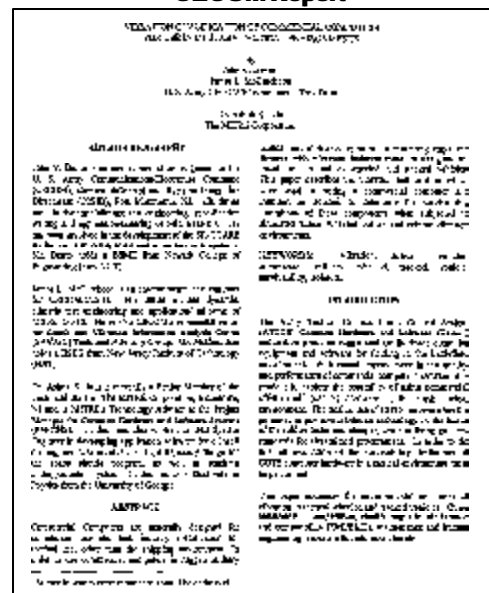

FM10 SERIES

Natural frequency	10-25 Hz	
Transmissibility at resonance	2.5 Max.	
Axial/Radial frequency ratio	1:0.8 approx.	
Resilient element	Neoprene or Silicone	
Damping medium	VHDS silicone gel	
Metal parts	Stainless steel, passivated	
Operating temperature	-40 to +195 deg.F -40 to +90 deg.C	
Weight	5.3 oz (148 grams)	
Part Number	Load Rating	
	Vehicular	Airborne
FM10-S01	3-8 lbs	0.5-5 lbs
FM10-N01	8-18 lbs	5-11 lbs



- 1 **M113, M577, M1A1, M1A2, M109A6, BRADLEY:** Tested and specified by CECOM/TACOM for use per MIL-STD-810E for protection of COTS equipment

Characteristics

- 1 Withstands high amplitude vibration inputs
- 1 0.5 inch shock travel capability
- 1 Outstanding dynamic fatigue life
- 1 High damping ratio, C/Cc = .20 critical damping
- 1 Axial-to-radial stiffness ratio of 1:0.6
- 1 Less than 1.5% drift over 3 years under nominal load

Environment

- 1 Operational temperature range of -40° to +195°F (-40°C to +90°C)
- 1 Ozone, corrosion and fungus resistant.

Installation

- 1 No special tools required
- 1 Can be made fail-safe by addition of a restraining strap
- 1 Base (compression) or angled shear-compression mounting

How to order

- 1 See load rating table for standard isolator
- 1 Restraining strap available
- 1 Metric version: specify suffix M for M5 threaded core

CECOM report

A CECOM report titled " **Vibration qualification of commercial computers for use in military tactical environments** " documents the results obtained by CECOM during an extensive test program. Copy of the report is available from Shock-Tech, please ask for document FM-CECOM/001

Applications

- 1 Protection of commercial grade ground mobile and **COTS electronics on tracked vehicles** against military shock and vibration specifications
- 1 Airborne electronics
- 1 Shipboard equipment
- 1 Trays and rack systems
- 1 Meets MIL-STD-810E shock and vibration environments including ON THE MOVE requirements

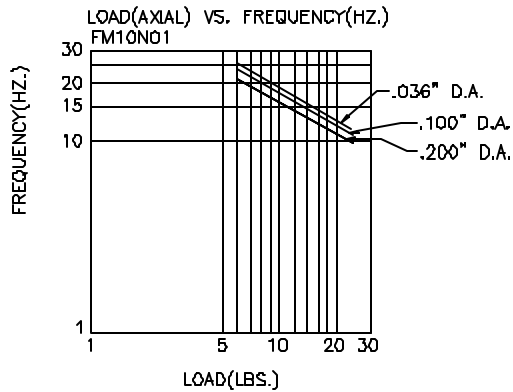
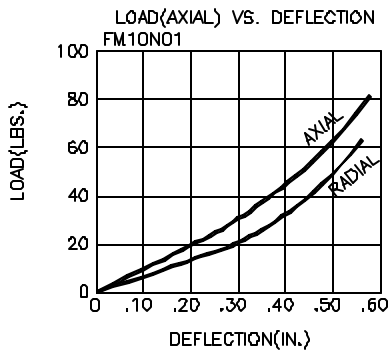
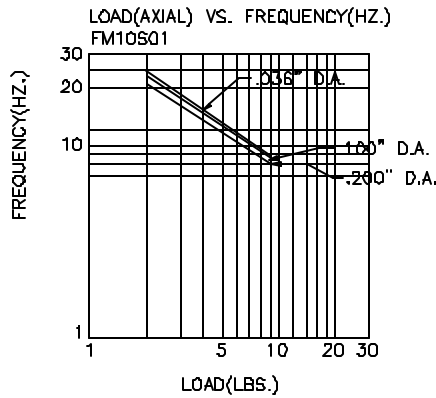
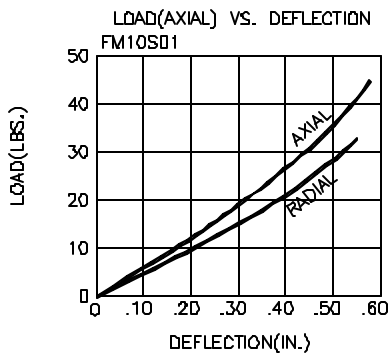
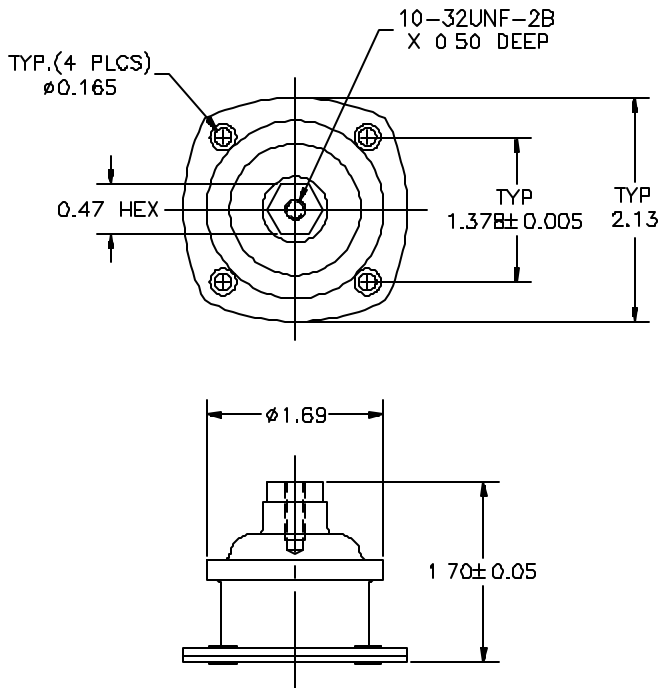

FM20 SERIES

Natural frequency	10-25 Hz	
Transmissibility at resonance	2.5 Max.	
Axial/Radial frequency ratio	1:0.7 approx.	
Resilient element	Neoprene	
Damping medium	VHDS silicone gel	
Metal parts	Stainless steel, passivated	
Operating Temperature	-40 to + 195 deg.F -40 to + 90 deg.C	
Weight	8 oz (227 grams)	
Part Number	Load Rating	
	Vehicular	Airborne
FM20-N01	18-33 lbs	13-18 lbs



1 **M113, M577, M1A1, M1A2, M109A6, BRADLEY:** Tested and specified by CECOM/TACOM for use per MIL-STD-810E for protection of COTS equipment

Characteristics

- 1 Withstands high amplitude vibration inputs
- 1 0.5 inch Shock travel capability
- 1 Outstanding dynamic fatigue life
- 1 High vibration damping ratio, C/Cc = .20
- 1 Axial-to-radial stiffness ratio of 1:0.5
- 1 Less than 1.5% drift over 3 years under nominal load

Environment

- 1 Operational temperature range of -40° to +195°F (-40°C to +90°C)
- 1 Ozone, corrosion and fungus resistant

Installation

- 1 No special tools required
- 1 Can be made fail-safe by addition of a restraining strap
- 1 Base (compression) or angled shear-compression mounting

How to order

- 1 See load rating table for standard isolator
- 1 Restraining strap available
- 1 Metric Version: specify suffix M for M6 threaded core

CECOM report

A CECOM report titled " **Vibration qualification of commercial computers for use in military tactical environments** " documents the results obtained by CECOM during an extensive test program. Copy of the report is available from Shock-Tech, please ask for document FMCECOM/001

Applications

- 1 Protection of commercial grade ground mobile and **COTS electronics on tracked vehicles** against military shock and vibration specifications
- 1 Airborne electronics
- 1 Shipboard equipment
- 1 Trays and rack systems
- 1 Meets MIL-STD-810E shock and vibration environments including ON THE MOVE requirements

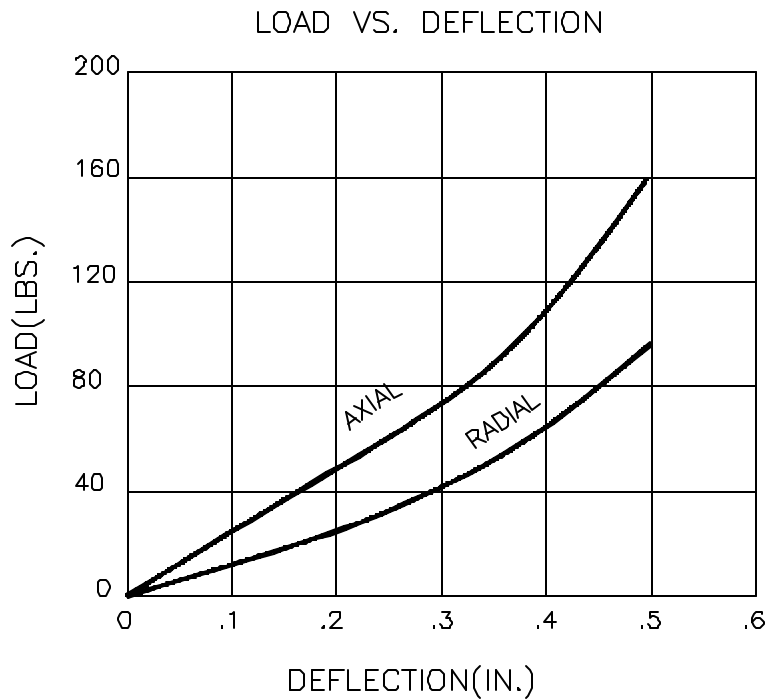
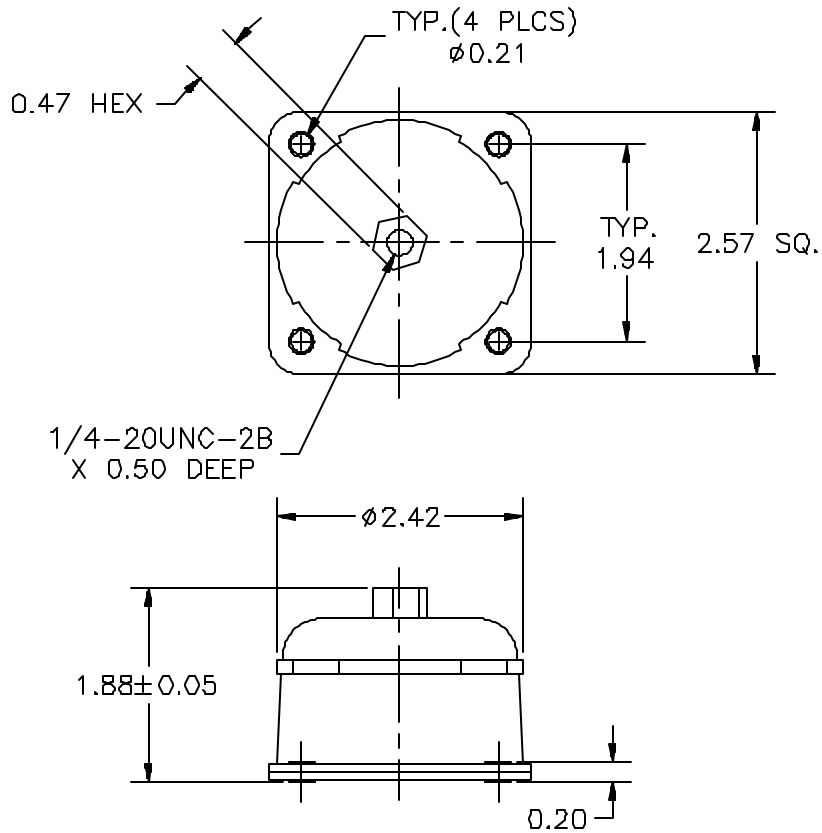

FM25 SERIES

Natural frequency	6-10 Hz
Transmissibility at resonance	2.5 Max.
Axial/Radial frequency ratio	1:1 approx.
Resilient element	Silicone
Damping medium	VHDS silicone gel
Metal parts	Stainless steel, passivated
Operating temperature	-40 to +195 deg.F -40 to +90 deg.C
Weight	8 oz (227 grams)
Load Rating	11-17 lbs
Part Number	FM25-S01M



- 1 **M113, M577, M1A1, M1A2, M109A6, BRADLEY:** Tested and specified by CECOM/TACOM for use per MIL-STD-810E for protection of COTS equipment

Characteristics

- 1 Withstands high amplitude vibration inputs
- 1 0.5 inch shock travel capability
- 1 Outstanding dynamic fatigue life
- 1 High damping ratio, C/Cc = .20
- 1 Axial-to-radial stiffness ratio of 1:0.9
- 1 Less than 1.5% drift over 3 years under nominal load

Environment

- 1 Operational temperature range of -40° to +195°F
- 1 Ozone, corrosion and fungus resistant

Installation

- 1 No special tools required
- 1 Can be made fail-safe by addition of a restraining strap
- 1 Base (compression) or angled (shear-compression) mounting

How to order

- 1 See load rating table for standard isolator
- 1 Restraining strap available

CECOM report

A CECOM report titled " **Vibration qualification of commercial computers for use in military tactical environments** " documents the results obtained by CECOM during an extensive test program. Copy of the report is available from Shock-Tech, please ask for document FM-CECOM/001

Applications

- 1 Protection of commercial grade ground mobile and **COTS electronics on tracked vehicles** against military shock and vibration specifications
- 1 Airborne electronics
- 1 Shipboard equipment
- 1 Trays and rack systems
- 1 Meets MIL-STD-810E shock and vibration environments including ON THE MOVE requirements

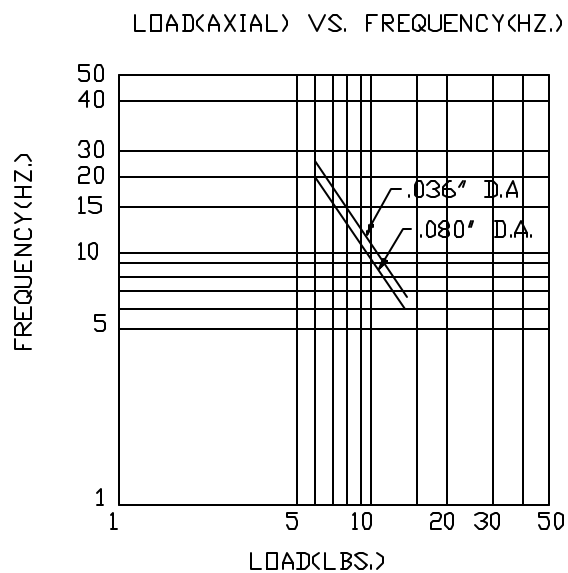
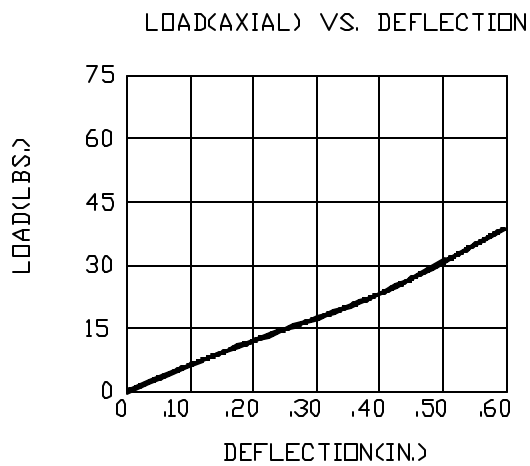
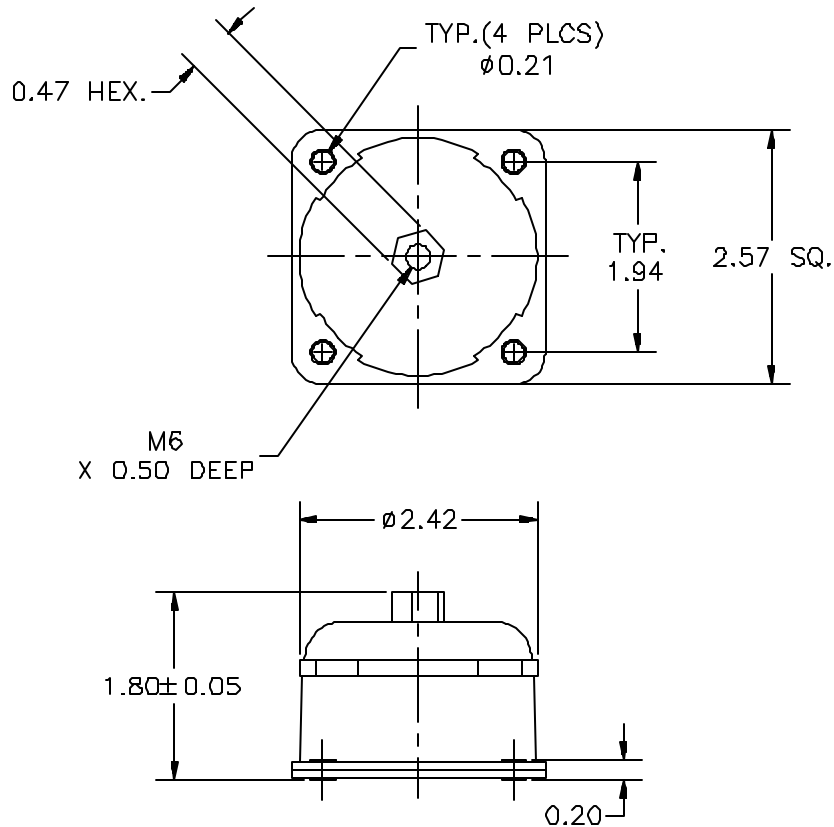

FM26 SERIES

Natural frequency	6-10 Hz
Transmissibility at resonance	2.5 Max.
Axial/Radial frequency ratio	1:1 approx.
Resilient element	Silicone
Damping medium	VHDS silicone gel
Metal parts	Stainless steel, passivated
Operating temperature	-40 to +195 deg.F -40 to +90 deg.C
Weight	8 oz (227 grams)
Load Rating	6-11 lbs
Part Number	FM26-S01M



- 1 **HUMVEE:** tested and specified by CECOM/TACOM for use per MIL-STD-810E for protection of COTS equipment

CECOM report

A CECOM report titled " **Vibration qualification of commercial computers for use in military tactical environments** " documents the results obtained by CECOM during an extensive test program. Copy of the report is available from Shock-Tech, please ask for document FM-CECOM/001

Applications

- 1 Protection of commercial grade ground mobile and **COTS electronics on wheeled vehicles** against military shock and vibration specifications
- 1 Airborne electronics
- 1 Shipboard equipment
- 1 Trays and rack systems
- 1 Meets MIL-STD-810E shock and vibration requirements including ON THE MOVE requirements

Characteristics

- 1 Withstands high amplitude vibration inputs
- 1 0.5 inch shock travel capability
- 1 Outstanding dynamic fatigue life
- 1 High damping ratio, C/Cc = .20
- 1 Axial-to-radial stiffness ratio of approximately 1:1
- 1 Less than 1.5% drift over 3 years under nominal load

Environment

- 1 Operational temperature range of -40° to +195°F
- 1 Ozone, corrosion and fungus resistant

Installation

- 1 No special tools required
- 1 Can be made fail-safe by addition of a restraining strap
- 1 Base (compression) or angled (shear-compression) mounting

How to order

- 1 See load rating table for standard isolator
- 1 Restraining strap available upon request

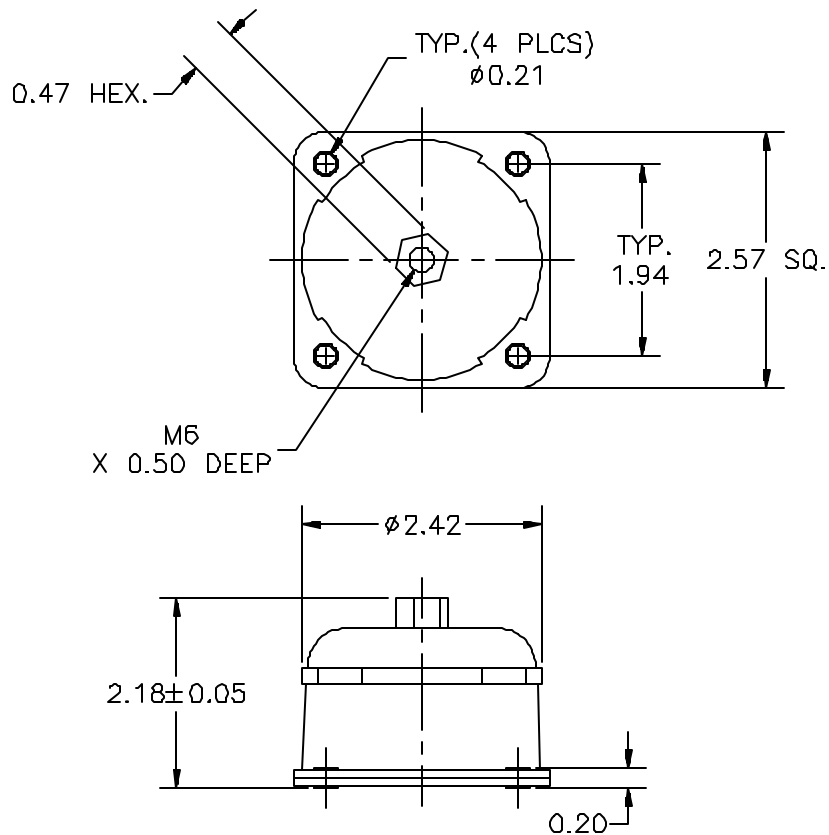

LOAD VS. DEFLECTION

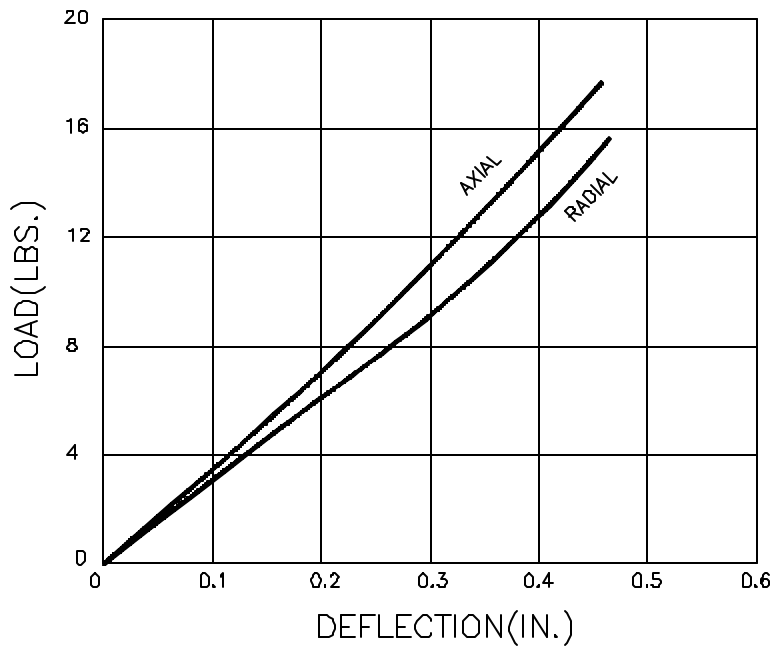

FM76, FM77 & FM78 SERIES

Natural frequency	10-25 Hz	
Transmissibility at resonance	3 Max.	
Axial/Radial frequency ratio	1:0.8 approx.	
Resilient element	Neoprene	
Damping medium	VHDS silicone gel	
Metal parts	Stainless Steel, passivated	
Operating temperature	-40 to +195 deg.F -40 to +90 deg.C	
Weight	FM76: 1 lb (454 grams)	
	FM77: 2 lbs (908 grams)	
	FM78: 4 lbs (1816 grams)	
Part Number	Load Rating	
	Vehicular	Airborne
FM76-N01M	30-40 lbs	15-25 lbs
FM76-N02M	40-60 lbs	20-45 lbs
FM77-N01M	44-110 lbs	
FM78-N01M	110-220 lbs	
FM78-N02M	200-290 lbs	

Applications

- 1 Ground mobile electronics, off-road vehicles
- 1 Computer units on tracked vehicles
- 1 Airborne electronics
- 1 Shipboard equipment
- 1 Trays and rack systems
- 1 Protection of commercial grade computer against military shock and vibration environments

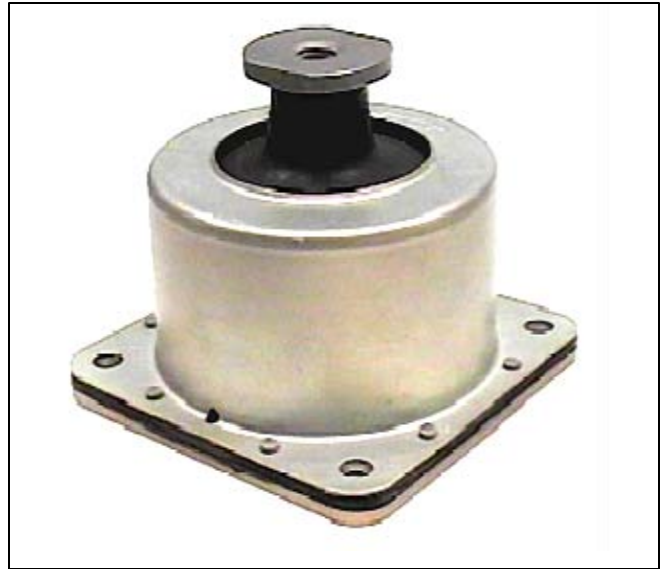

Characteristics

- 1 Withstands high amplitude vibration inputs
- 1 0.5 inch Shock travel capability
- 1 Outstanding dynamic fatigue life
- 1 High damping ratio, C/Cc = .20
- 1 The FM77-01 attenuates a 30 G, 11 millisecond ½ sine shock to 24 G's and a 40 G, 6 millisecond half sine shock to 14 G's
- 1 The FM78 series attenuates a 22 G, 11 millisecond and a 40, 6 millisecond ½ sine shock
- 1 Axial-to-radial stiffness ratio of 1:0.6
- 1 Less than 1.5% drift over 3 years under nominal load

Environment

- 1 Operational temperature range of -40° to +195°F (-40°C to +90°C)
- 1 Ozone, corrosion and fungus resistant.

Installation

- 1 No special tools required
- 1 Can be made fail-safe by addition of a restraining strap
- 1 Base (compression) or angled shear-compression mounting

How to order

- 1 See load rating table for standard isolator
- 1 Restraining strap available
- 1 Metric thread standard

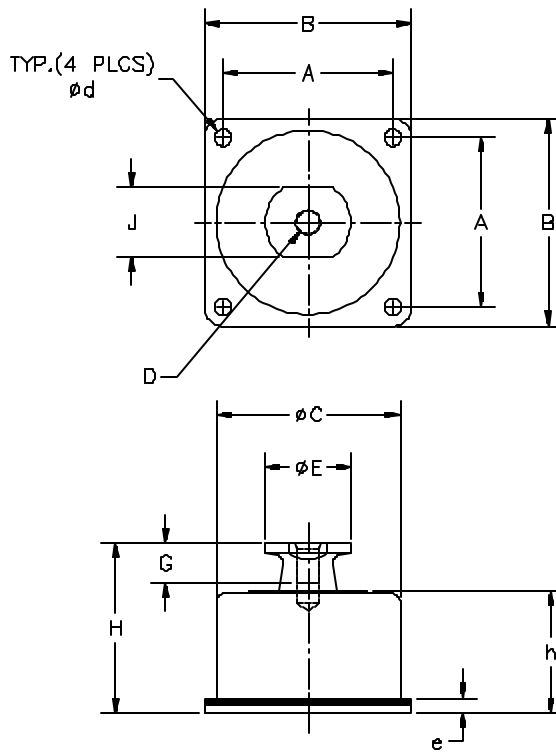

Part No	Dimensions in inches										
	H	h	e	G	C	E	D	B	A	J	d
FM76	2.87	1.93	.28	.75	2.76	1.18	M10	3.03	2.50	.94	.36
FM77	3.46	2.44	.33	.94	3.78	1.57	M12	4.33	3.46	1.34	.36
FM78	4.3	3.05	.37	.98	4.61	2.13	M16	5.20	4.25	1.73	.60

