

# TM10 SERIES

Natural frequency	20-40 Hz	
Transmissibility at resonance	4 Max. (VHDS Silicone)	
Axial/Radial frequency ratio	1:1 approx.	
Resilient element	VHDS Silicone or Fluorosilicone	
Metal parts	Aluminum	
Operating temperature	-67 to +300 deg.F (VHDS Silicone)	
Weight	1.1 oz. (30 grams)	
Part Number	Static load (lbs)	Nat Frequency at .60 in.DA
TM10-S01 and -F01	1	22 HZ
TM10-S02 and -F02	2	22HZ
TM10-S03 and -F03	3	22HZ
TM10-S04 and -F04	5	22HZ
TM10-S05 and -F05	7	22HZ

## Applications

- 1 Shipboard electronics
- 1 Navigation and communication electronics
- 1 Racks and trays
- 1 Light weight electro-mechanical devices
- 1 Avionics, counter-measure systems

## Characteristics

- 1 All-Attitude isolator
- 1 Axial-to-radial stiffness ratio of approx. 1:1
- 1 Low resonant transmissibility (4.0 max.with VHDS Silicone)
- 1 Lightweight and fail safe
- 1 Capable of attenuating while supporting load up to 5g,s
- 1 Meets crash safety requirements of MIL-E-5400 (30g-11 millisecond ½ sine pulse shock)

Specifications are subject to change without notice.



## Environment

- 1 From - 67°F to + 300°F ( - 55°C to + 150°C) operational temperature range
- 1 From - 100°F to + 300°F ( - 75°C to + 150°C) in storage temperature range (VHDS Silicone)
- 1 Meets MIL-E-5400 requirements for resistance to ozone, humidity, salt spray, fungus, etc.
- 1 Meets MIL-S-901 light weight Grade B Navy high-impact shock test requirements
- 1 Sine vibration maximum input at resonance of .06 in. D.A.

## Installation

- 1 No special tools required
- 1 1.41 in. center to center tie-down hole pattern in base for standard hardware
- 1 8-32 UNC-2B center core
- 1 Alternate mounting solutions, please inquire

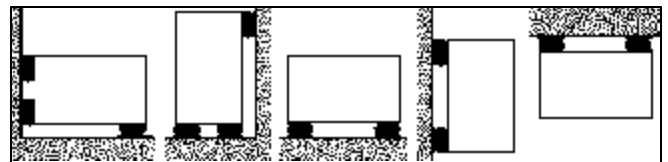

## How to order

- 1 The letter S indicates that the elastomer is VHDS silicone. The letter F indicates that the elastomer is fluorosilicone
- 1 The standard finish is a grey enamel paint. Non standard finishes and designs available on special order
- 1 For non standard items, contact Shock-Tech.

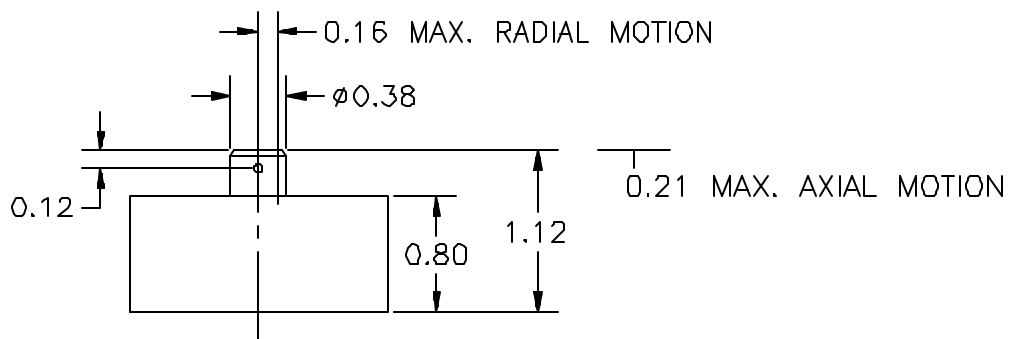
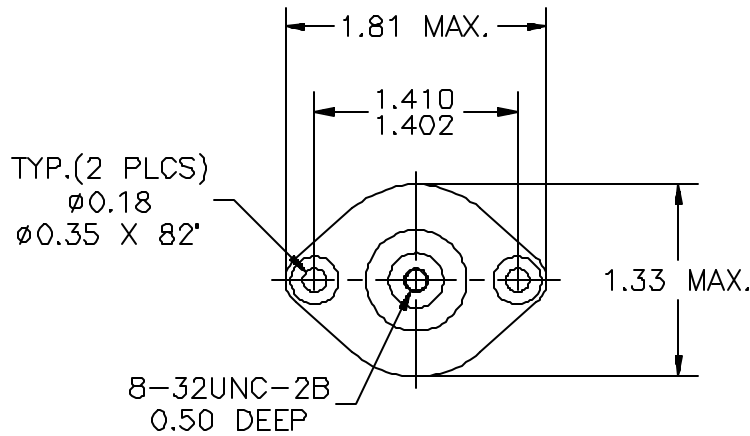

TRANSMISSIBILITY vs. FREQUENCY  
INPUT SINE 0.060 INCHES D.A

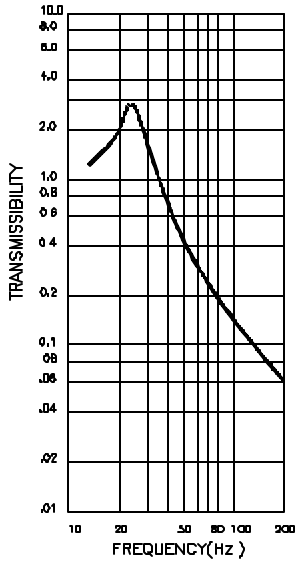

LOAD (AXIAL) vs. DEFLECTION

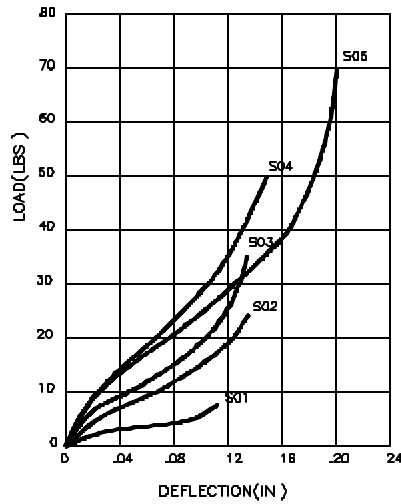

LOAD (RADIAL) vs. DEFLECTION

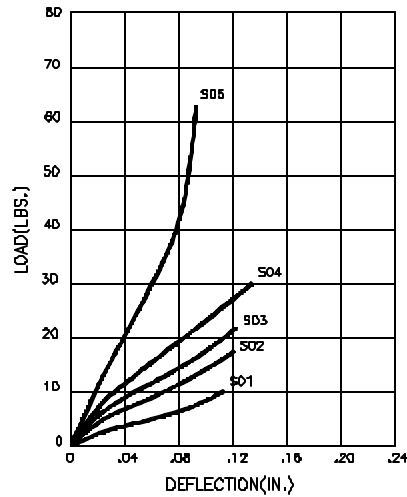

# TM11 SERIES

Natural frequency	20-40 Hz	
Transmissibility at resonance	4.5 Max. (VHDS Silicone)	
Axial/Radial frequency ratio	1:1 approx.	
Resilient element	VHDS Silicone or Fluorosilicone	
Metal parts	Aluminum	
Operating temperature	-67 to +300 deg.F (VHDS Silicone)	
Weight	2.7 oz. (77 grams)	
Part Number	Static load (lbs)	Nat Frequency at .60 in.DA
TM11-S01 and -F01	10	22 HZ
TM11-S02 and -F02	15	22HZ
TM11-S03 and -F03	20	22HZ



## Environment

- 1 From - 67°F to + 300°F ( - 55°C to + 150°C) operational temperature range
- 1 From - 100°F to + 300°F ( - 75°C to + 150°C) in storage temperature range (VHDS Silicone)
- 1 Meets MIL-E-5400 requirements for resistance to ozone, humidity, salt spray, fungus, etc.
- 1 Meets MIL-S-901 light weight Grade B Navy high-impact shock test requirements
- 1 Sine vibration maximum input at resonance of .06 in. D.A.

## Installation

- 1 No special tools required
- 1 1.375 in. center to center tie-down hole pattern in base for standard hardware
- 1 1/4-28 UNF-2B center core, 0.50 in. deep.



## Applications

- 1 Shipboard electronics
- 1 Navigation and communication electronics
- 1 Racks and trays
- 1 Light weight electro-mechanical devices
- 1 Avionics, counter-measure systems

## Characteristics

- 1 All-Attitude
- 1 Axial-to-radial stiffness ratio of approx. 1:1
- 1 Low resonant transmissibility (4.5 max. with VHDS Silicone)
- 1 Lightweight and failsafe
- 1 Capable of attenuating while supporting loads up to 5g"s.
- 1 Meets crash safety requirements of MIL-E-5400 (30g-11 millisecond 1/2 sine pulse shock)

## How to order

- 1 The letter S indicates that the elastomer is VHDS silicone. The letter F indicates that the elastomer is fluorosilicone
- 1 The standard finish is a grey enamel paint. Non standard finishes and designs available on special order
- 1 For non standard items, contact Shock-Tech.

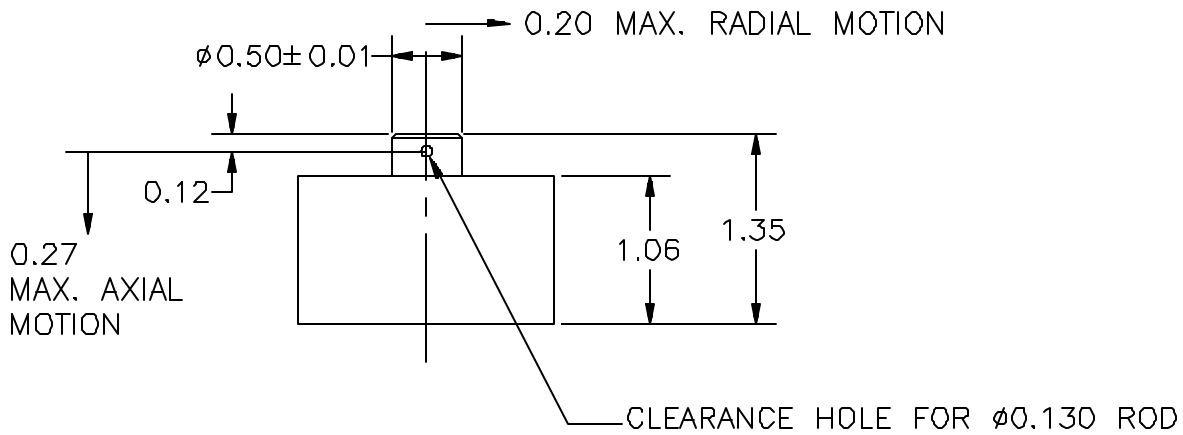
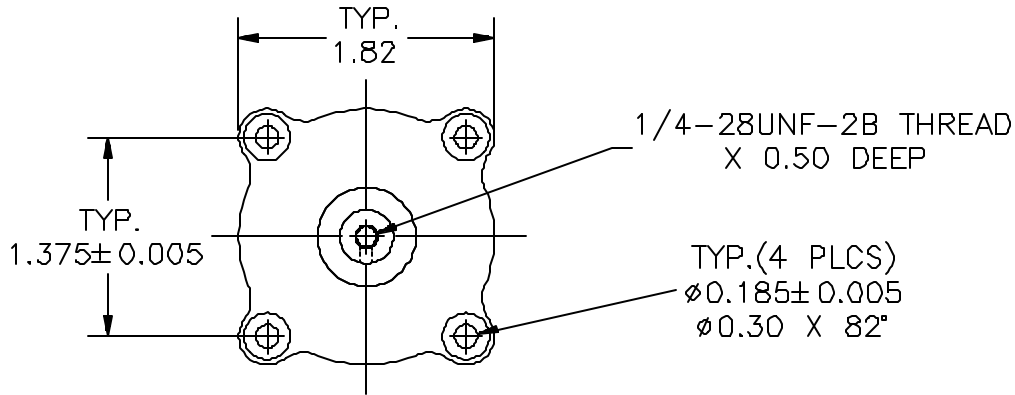

TRANSMISSIBILITY vs. FREQUENCY  
INPUT SINE 0.060 INCHES DIA.

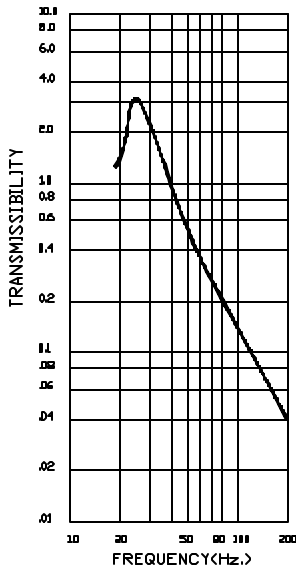

LOAD (AXIAL) vs. DEFLECTION

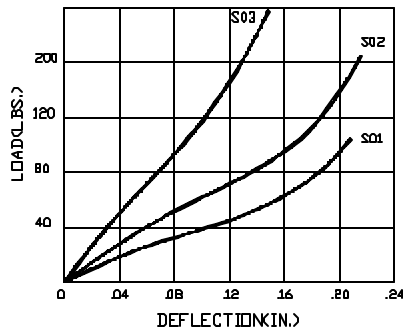

LOAD (RADIAL) vs. DEFLECTION

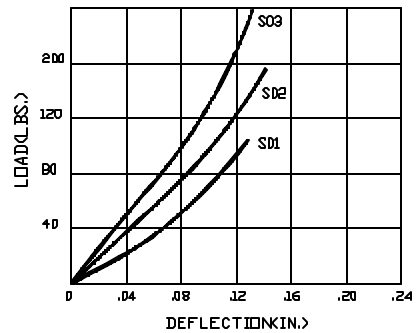

# TM22 SERIES

Natural frequency	20-40 Hz
Loaded height	0.91 in. minimum
Transmissibility at resonance	4 Max.
Axial/Radial frequency ratio	1:1 approx.
Resilient element	VHDS Silicone
Metal parts	Aluminum Zinc plated steel core
Operating temperature	-67 to +300 deg.F (Silicone) -55 to +150 deg.C
Weight	1.1 oz. (30 grams)
Part Number	Load Rating Static load (lbs) (Max.)
TM22-S01	1
TM22-S02	2
TM22-S03	3
TM22-S04	5

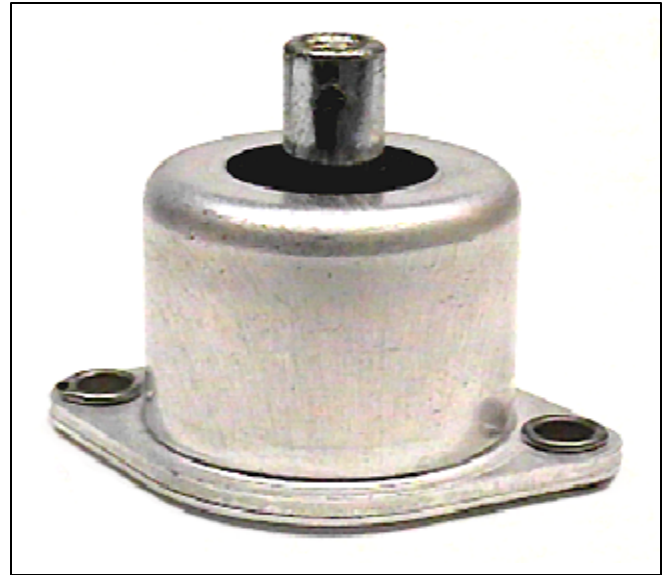

## Environment

- 1 -67°F to + 300°F ( - 55°C to + 150°C) operational temperature range
- 1 -100°F to + 300°F ( - 75°C to + 150°C) storage temperature range
- 1 Meets MIL-E-5400 requirements for resistance to ozone, humidity, salt spray, fungus, etc.
- 1 Meets MIL-S-901 light weight Grade B Navy high-impact shock test requirements
- 1 Sine vibration input at resonance can be as high as .06 in. D.A.

## Installation

- 1 No special tools required
- 1 1.41 in. center to center tie-down hole pattern in base for standard hardware
- 1 Center hole is tapped for standard hardware

## Applications

- 1 Shipboard electronics
- 1 Navigation and communication electronics
- 1 Racks and trays
- 1 Light weight electro-mechanical devices
- 1 Avionics, counter-measure systems

## Characteristics

- 1 All-Attitude
- 1 Axial-to-radial stiffness is approximately 1:1
- 1 Low resonant transmissibility (4.0 max. with VHDS Silicone)
- 1 Lightweight and failsafe
- 1 Capable of attenuating while supporting loads up to 5g's
- 1 Meets crash safety requirements of MIL-E-5400 (30g-11 millisecond ½ sine pulse shock)



## How to order

- 1 See load rating table for standard isolator
- 1 For non standard items, contact Shock-Tech.

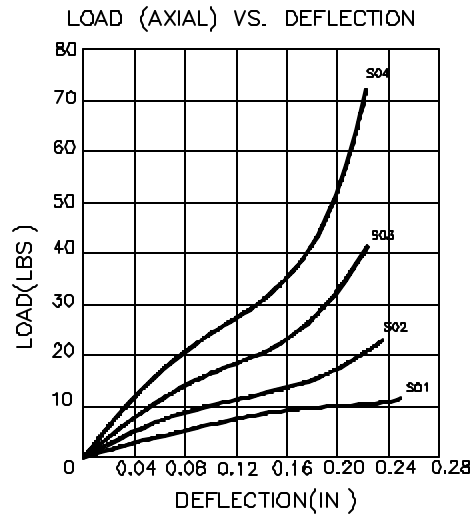
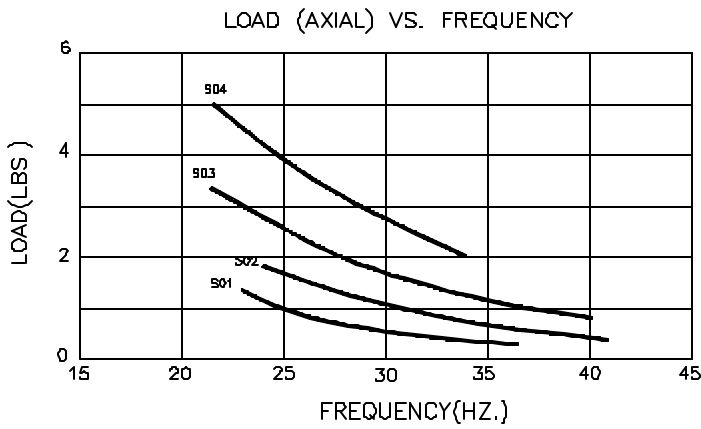
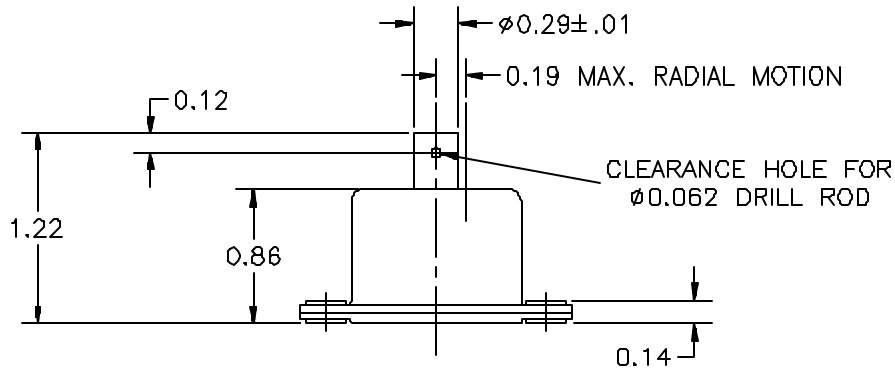
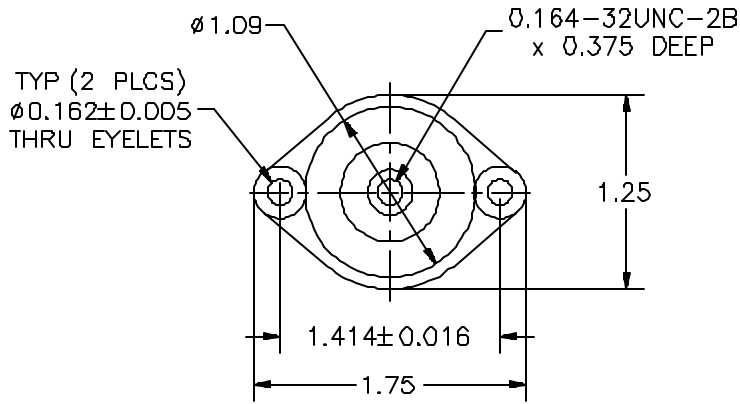

# TM44 SERIES

Natural frequency	20-40 Hz
Loaded height	1.19 in. minimum
Transmissibility at resonance	4 Max.
Axial/Radial frequency ratio	1:1 approx.
Resilient element	VHDS Silicone
Metal parts	Stainless steel cup and plate aluminum core standard
Operating temperature	-67 to +300 deg. F -55 to +150 deg. C
Weight	2.8 oz. (78 grams)
Part Number	Load Rating Static load (lbs) (Max.)
TM44-S01	10
TM44-S02	15
TM44-S03	20



## Environment

- 1 - 67°F to + 300°F ( - 55°C to + 150°C) operational temperature range
- 1 - 100°F to + 300°F ( - 75°C to + 150°C) storage temperature range
- 1 Meets MIL-E-5400 requirements for resistance to ozone, humidity, salt spray, fungus, etc.
- 1 Meets MIL-S-901 light weight Grade B Navy high-impact shock test requirements
- 1 Sine vibration input at resonance can be as high as .06 in. D.A.

## Installation

- 1 No special tools required
- 1 Tie-down hole pattern in base for standard hardware
- 1 0.250-28 UNF-2B Center core

## Applications

- 1 Shipboard electronics
- 1 Navigation and communication electronics
- 1 Racks and trays
- 1 Light weight electro-mechanical devices
- 1 Avionics, counter-measure systems
- 1 Electronic gear on board vehicle

## Characteristics

- 1 All-Attitude
- 1 Axial-to-radial stiffness is approximately 1:1
- 1 Low resonant transmissibility (4.0 max.)
- 1 Lightweight and failsafe
- 1 Capable of attenuating while supporting loads up to 5g's
- 1 Meets crash safety requirements of MIL-E-5400 (30g-11 millisecond ½ sine pulse shock)

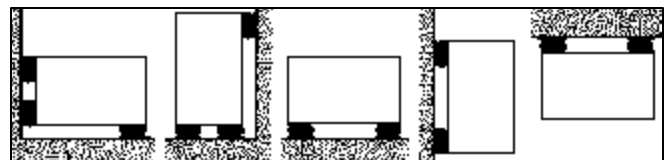

## How to order

- 1 Standard mount: see table
- 1 The core of the TM44 isolator comes standard with a clearance hole for a .125 dia drill rod. Wrench flats are optional (same part number with a suffix X). [example: TM44-S01X]
- 1 For non standard items, contact Shock-Tech.

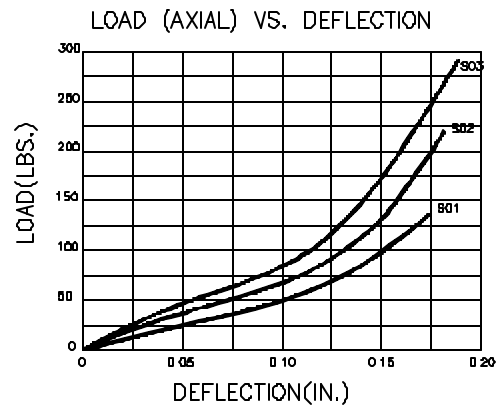
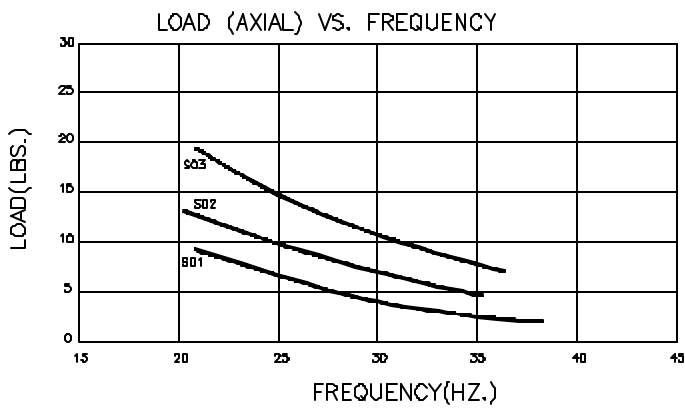
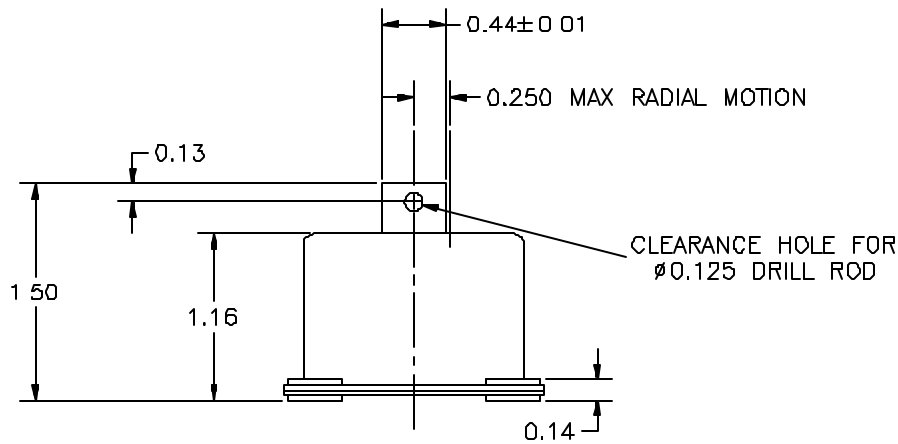
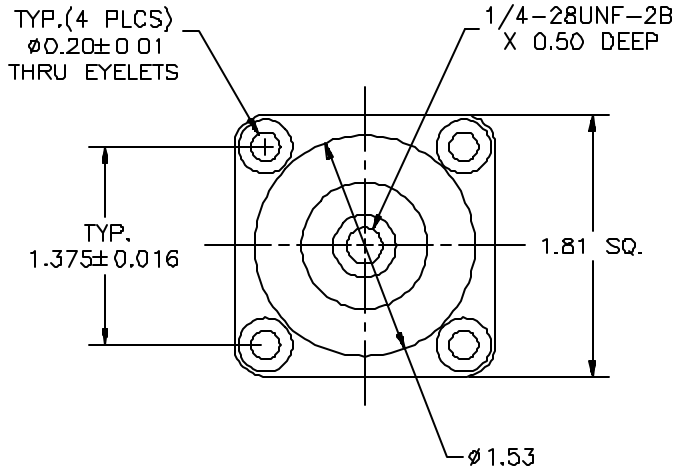

# TM64 SERIES

Natural frequency	15-35 Hz
Loaded height	1.25 in. minimum
Transmissibility at resonance	4 Max.
Axial/Radial frequency ratio	1:1 approx.
Resilient element	VHDS Silicone
Metal parts	Stainless steel cup and aluminum core standard
Operating temperature	-67 to +300 deg. F -55 to +150 deg. C
Weight	5.3 oz. (148 grams)
Part Number	Load Rating Static load (lbs) (Max.)
TM64-S00	20
TM64-S01	35
TM64-S02	50
TM64-S03	80

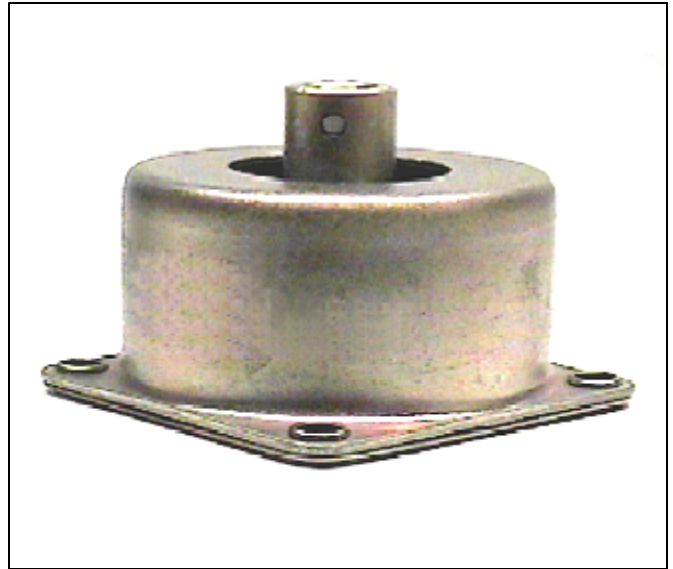

## Environment

- 1 - 67°F to + 300°F (-55°C to + 150°C) operational temperature range
- 1 - 100°F to + 300°F (-75°C to + 150°C) in storage temperature range
- 1 Meets MIL-E-5400 environmental requirements (ozone, humidity, salt spray, fungus)
- 1 Meets MIL-S-901 light weight Grade B Navy high-impact shock test requirements and MIL-STD-167
- 1 Sine vibration maximum input at resonance of .06 in. D.A.

## Installation

- 1 No special tools required
- 1 Tie-down hole pattern in base for standard hardware

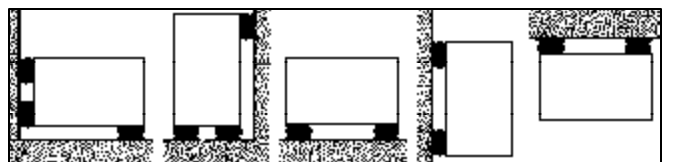

## Applications

- 1 Shipboard electronics
- 1 Navigation and communication electronics
- 1 Light weight electro-mechanical devices
- 1 Avionics, counter-measure systems
- 1 Electronic gear on board vehicle

## Characteristics

- 1 All-Attitude
- 1 Axial-to-radial stiffness ratio of approx. 1:1
- 1 Lightweight and failsafe cup construction
- 1 Capable of attenuating while supporting loads up to 5g's.
- 1 Meets crash safety requirements of MIL-E-5400 (30g-11 millisecond ½ sine pulse shock)

## How to order

- 1 Standard mount: see table
- 1 The core of the TM64 isolator comes standard with a clearance hole for a .125 dia drill rod. Wrench flats are optional (same part number with a suffix X). [example: TM64-S01X]
- 1 Non-standard materials and finishes available
- 1 For non standard items, contact Shock-Tech.

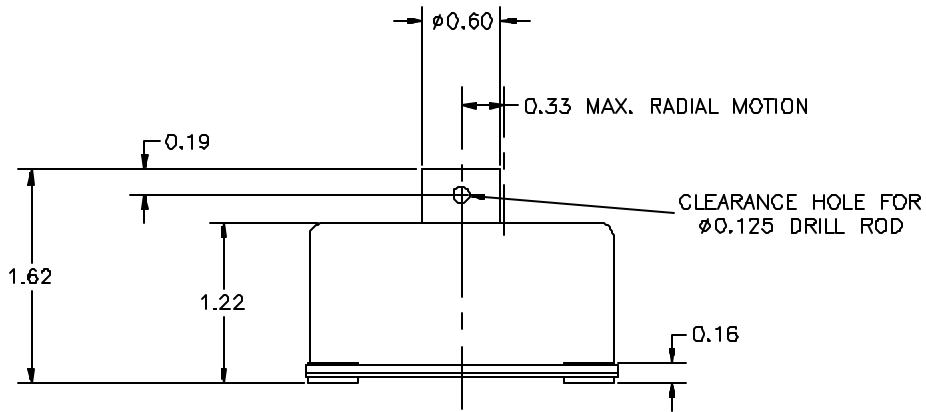
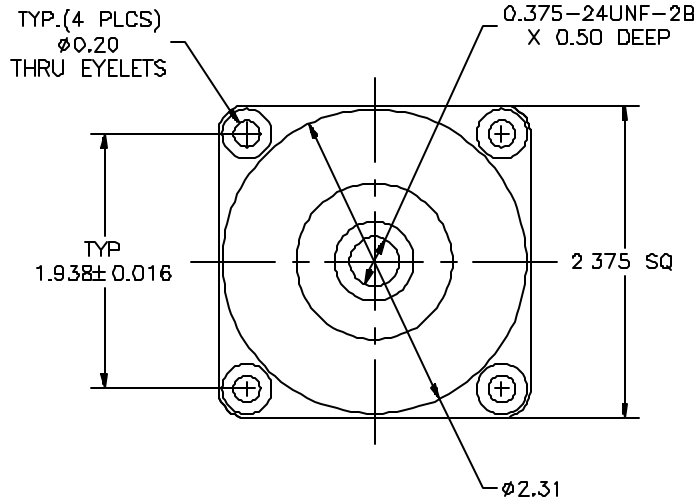

LOAD (AXIAL) VS. FREQUENCY

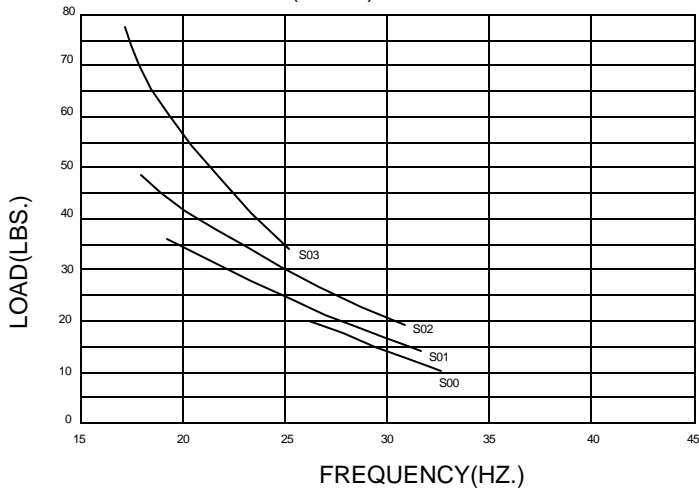

LOAD (AXIAL) VS. DEFLECTION

